

TFLEX MODULE

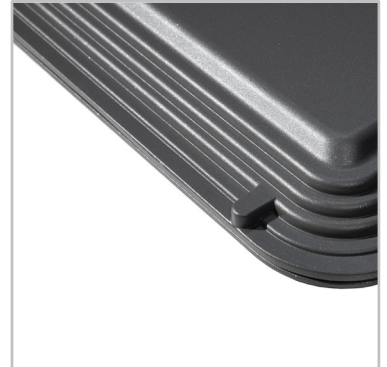

Modular optical solution to enhance your tunnel lighting

TFLEX MODULE is part of the TFLEX tunnel lighting solutions, providing the most flexible optical units that can adapt to all tunnel projects.

This innovative optical module can be assembled directly or remotely with up to three other modules. This modular approach offers the possibility to create various lighting configurations to suit any tunnel geometry.

TFLEX MODULE integrates the latest optimised optics to provide perfect lighting levels and visibility all along the tunnel.

A double circuit approach in combination with an advanced control management system delivers outstanding performance, leading to unparalleled energy savings.

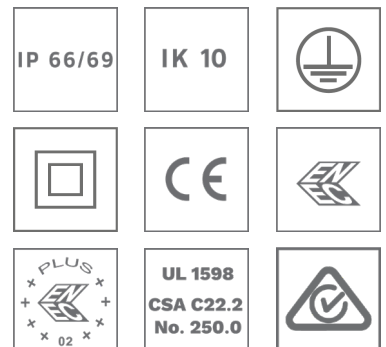

Concept

The TFLEX MODULE has been developed to maximise efficiency and flexibility in tunnels. This unique modular optic system offers flexible optical units, a wide range of mounting options, smart cabling, quick-on QPD connectors to considerably improve visibility for drivers and to provide major operational benefits for tunnel managers

Part of the TFLEX lighting solutions, TFLEX MODULE provides a consistent solution that meets the lighting requirements for various tunnel zones (threshold, transition, interior and exit), the preferred lighting concept, the mounting requirements and the tunnel geometry.

Made of robust and sustainable materials (aluminium, steel and glass), TFLEX MODULE ensures long-lasting performance in the harshest tunnel environments.

TFLEX MODULE combines the energy efficiency of LED technology with the photometric performance of the latest LensoFlex® platform developed by Schröder. It integrates specific tunnel optics for symmetrical, pro-beam or counter-beam (CBL) lighting distributions to optimise lighting levels on road and wall surfaces while providing high visual comfort.

TFLEX MODULE has been developed to enable constant dimming with an optimised power factor. Designed with two electronic circuits, it can either be dimmed completely, partially or even have 50% of its LEDs switched off. This possibility not only maximises energy savings, it also extends the lifetime of the complete installation and reduces the need for disruptive maintenance.



TFLEX MODULE offers a flexible solution to create various lighting configurations to fit all tunnel geometries.



TFLEX MODULE uses tool-free, fire rated cables and connectors, reducing the installation time dramatically and improving quality and reliability.

TYPES OF APPLICATION

- TUNNELS & UNDERPASSES

KEY ADVANTAGES

- Flexibility: modular approach with wide range of lighting distributions
- Two electrical circuits for enhanced dimming possibilities, optimised power factor and longer lifespan
- High quality and robust materials
- Compact, lightweight and easy to install
- Designed for long-lasting performance
- LensoFlex®4 versatile solutions for high-end photometries maximising comfort and safety



Designed with two electronic circuits, TFLEX MODULE enables constant dimming with an optimised power factor.



TFLEX MODULE is made of robust and sustainable materials to ensure long-lasting performance in the harshest tunnel environments.

TFLEX MODULE | 1 Module



TFLEX MODULE | 2 Modules



TFLEX MODULE | 3 Modules





LensoFlex®4

LensoFlex®4 maximises the heritage of the LensoFlex® concept with a very compact yet powerful photometric engine based upon the addition principle of photometric distribution. The number of LEDs in combination with the driving current determines the intensity level of the light distribution. With optimised light distributions and very high efficiency, this fourth generation enables the products to be downsized to meet application requirements with an optimised solution in terms of investment.

LensoFlex®4 optics can feature backlight control to prevent intrusive lighting, or a glare limiter for high visual comfort.

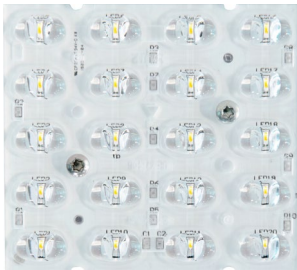

Advanced Tunnel System 4 (ATS 4)

The ATS 4 (Advanced Tunnel System 4) is a powerful tunnel lighting control system for precise remote dimming and switching of each individual connected luminaire, based on various tunnel parameter inputs (emergency exits, smoke extraction system, traffic cameras, etc.).

The ATS 4 permanently communicates with the Lumgates, an RS422 closed-loop device connected to the luminaire drivers, to control the light intensity and provide command/reporting features.



Advanced Tunnel System 4 DALI (ATS 4 DALI)

The Advanced Tunnel System 4 DALI provides the essential functions of the ATS 4 over a DALI network protocol, enabling dimming of luminaire clusters to be controlled collectively.

The ATS 4 DALI is the ideal solution to implement a reliable and powerful tunnel lighting control system with streamlined features and optimised costs.



Sensors and cameras

The ATS 4 can be connected to various sensors and cameras to permanently adjust the lighting levels to indoor and outdoor conditions and avoid any visual adaptation problems.



Tunnel Control System 4 (TCS 4)

The Tunnel Control System 4 (TCS 4) is a gateway ensuring the connection/control of the multiple ATS 4 controllers as well as the communication with the central management system of the tunnel infrastructure (SCADA) if applicable.



Lumgate V4

The Lumgate is a luminaire control unit that acts as an interface between the lighting management system and the tunnel luminaires or driver boxes. Connected to the luminaire drivers, it switches the drivers on/off, controls the light intensity and provides command/reporting features.

It is suitable for installation in driver boxes or directly in the luminaire. It communicates with the driver via 0-10V or DALI command. This brand new interface includes advanced Inrush Current Limitation Features and a 24 hour fail-safe repeat mode.



Jointly developed by Schröder and Phoenix Contact, the Advanced Tunnel System 4 (ATS 4) has been designed to control every lighting point or clusters of luminaires to perfectly adapt the lighting level according to conditions in the tunnel, to monitor the power consumption and to report the burning hours or any failure to facilitate maintenance. The system includes a self-commissioning feature and enables scenarios to be adapted remotely at any moment.

ADAPTIVE LIGHTING ACCORDING TO SPEED



The ATS 4 can be linked to a traffic monitoring system to obtain data regarding speed or density to adapt the lighting level according to safety standards. This option further reduces energy consumption and increases the lifetime of the installation while ensuring the best driving conditions for motorists.

PRECISE AND CONTINUOUS DIMMING

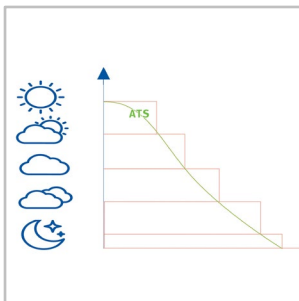

ATS 4 provides 25 different dimming levels to precisely adapt the lighting to the real needs. Without any over-lighting, the energy consumption is limited to what is absolutely necessary to ensure safe and comfortable driving conditions.

ADAPTIVE LIGHTING ACCORDING TO POLLUTION

Based on cleaning cycles, the ATS 4 can take into account the depreciation of the flux due to dirt accumulation to continuously provide the requested lighting level in the tunnel. No more, no less. This feature offers additional energy savings while providing safety and comfort for users.

FLEXIBILITY

Flexible redundancy offers security on multi-level applications, not only for the lighting.

PLUG AND PLAY COMMISSIONING

This control system is easy to install and configure. The tunnel lighting study can be directly imported into the ATS 4 control system. This unique feature, in combination with the auto-addressing of the Lumgates, leads to an extremely short commissioning time once the fixtures have been installed. The ATS 4 benefits from a complete set of toolless smart cables and connectors, allowing installers to speed up cabling and save valuable time on-site.

INTERACTION WITH THIRD PARTY SYSTEMS

Every command or signal sent to or coming from a tunnel component (emergency exit, smoke extraction system, traffic management system...) can be used to trigger a responsive lighting scenario. All of the tunnel equipment can be controlled through the same bus command.

MAXIMISED SAFETY

The system enables the easy set-up of emergency and disaster management scenarios.

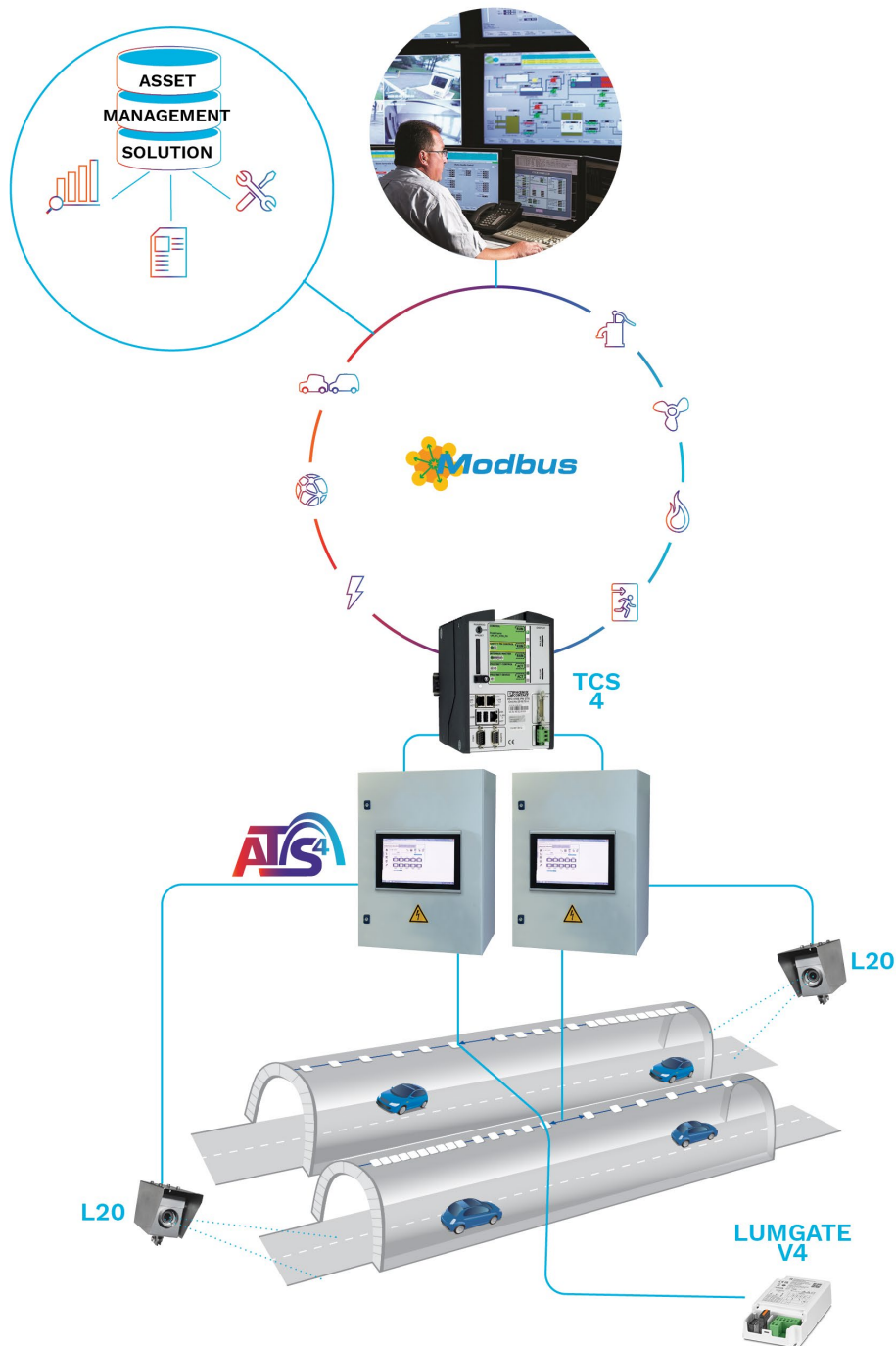

GENERAL INFORMATION

Circle Light label	Score ≥ 90 - The product fully meets circular economy requirements
CE mark	Yes
ENEC certified	Yes
ENEC+ certified	Yes
UL certified	Yes
RCM mark	Yes

HOUSING AND FINISH

Housing	Aluminium
Optic	PMMA
Protector	Tempered glass
Housing finish	<p>Polyester powder coating</p> <p>Standard polyester powder coating (C2-C3 according to the ISO 9223-2012 standard)</p> <p>Optional "seaside" polyester powder coating (C4 according to the ISO 9223-2012 standard)</p> <p>Optional "seafront" polyester powder coating with anodisation (C5-CX according to the ISO 9223-2012 standard)</p>
Standard colour(s)	AKZO grey 900 sanded
Tightness level	IP66/IP69
Impact resistance	IK 10
Vibration test	Compliant with modified IEC 68-2-6 (0.5G)

OPERATING CONDITIONS

Operating temperature range (Ta)	-30°C up to +55°C / -22° F up to 131°F
----------------------------------	--

· Depending on the luminaire configuration. For more details, please contact us.

ELECTRICAL INFORMATION

Electrical class	Class 1 US, Class I EU, Class II EU
Nominal voltage	220-240V – 50-60Hz 347-480V – 50-60Hz 277V – 50-60Hz
Surge protection options (kV)	10 20
Electromagnetic compatibility (EMC)	EN 55015 / EN 61000-3-2 / EN 61000-3-3 / EN 61547
Control protocol(s)	1-10V, DALI
Control options	Lumgate, Bi-power, Remote management
Associated control system(s)	Advanced Tunnel System 4 (ATS 4) Advanced Tunnel System 4 DALI (ATS 4 DALI)

· Electrical information given for the gear box

OPTICAL INFORMATION

LED colour temperature	4000K (Neutral White NW 740)
Colour rendering index (CRI)	>70 (Neutral White NW 740)

LIFETIME OF THE LEDS @ TQ 25°C

All configurations	100,000h - L97
--------------------	----------------

· Lifetime may be different according to the size/configurations. Please consult us.

DIMENSIONS AND MOUNTING

AxBxC (mm inch)	TFLEX MODULE 1 : 385x70x391 15.2x2.8x15.4 TFLEX MODULE 2 : 385x70x780 15.2x2.8x30.7 TFLEX MODULE 3 : 385x70x1170 15.2x2.8x46.1
Weight (kg lbs)	TFLEX MODULE 1 : 8.0 17.6 TFLEX MODULE 2 : 15.0 33.0 TFLEX MODULE 3 : 23.0 50.6
Mounting possibilities	Hook(s) for suspension Surface mounting Wall-mounted

· Size and weight may be different according to the configuration. Please consult us for more information.

· Various dedicated brackets, swiveling and direct mountings. Please consult the installation sheets.

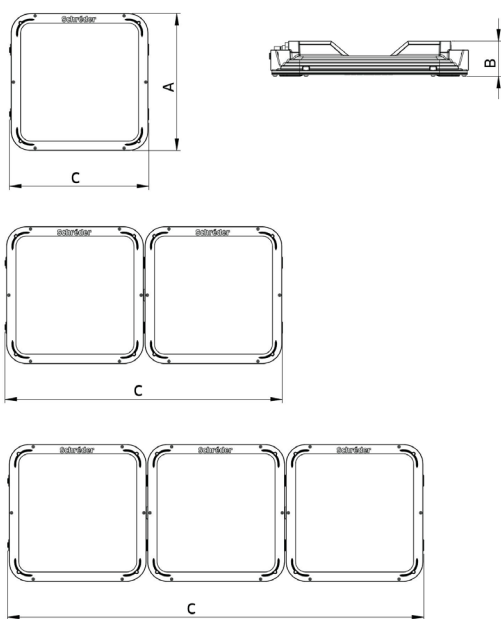

TFLEX MODULE | Fixed brackets - more details in the installation sheet

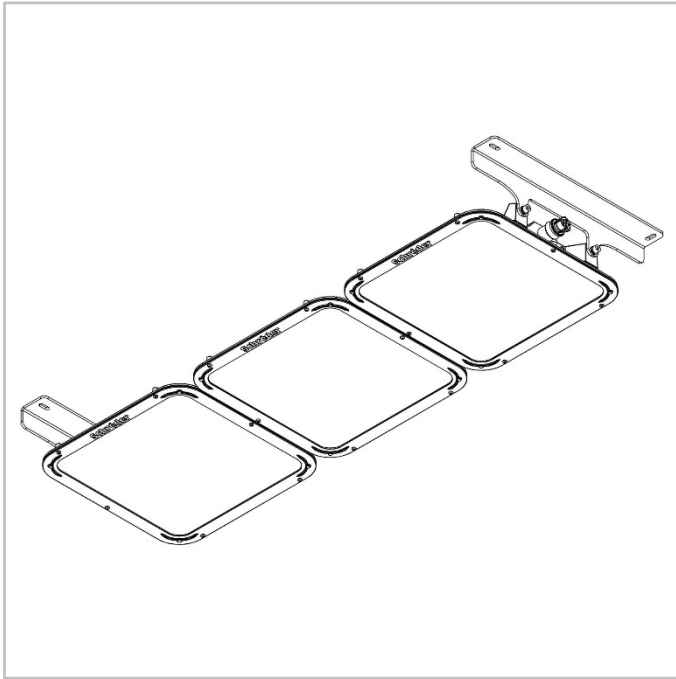

TFLEX MODULE | Pull-out swivelling mounting - more details in the installation sheet

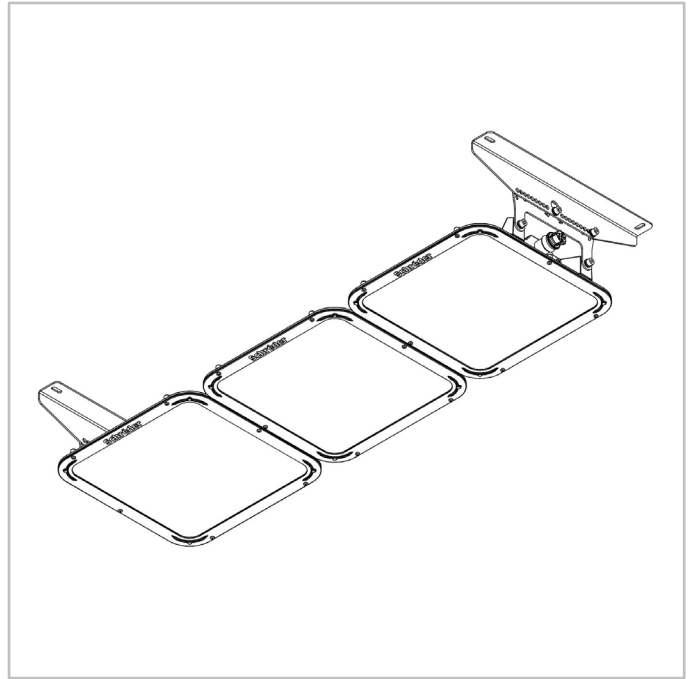

TFLEX MODULE | Adjustable swivelling mounting - more details in the installation sheet.

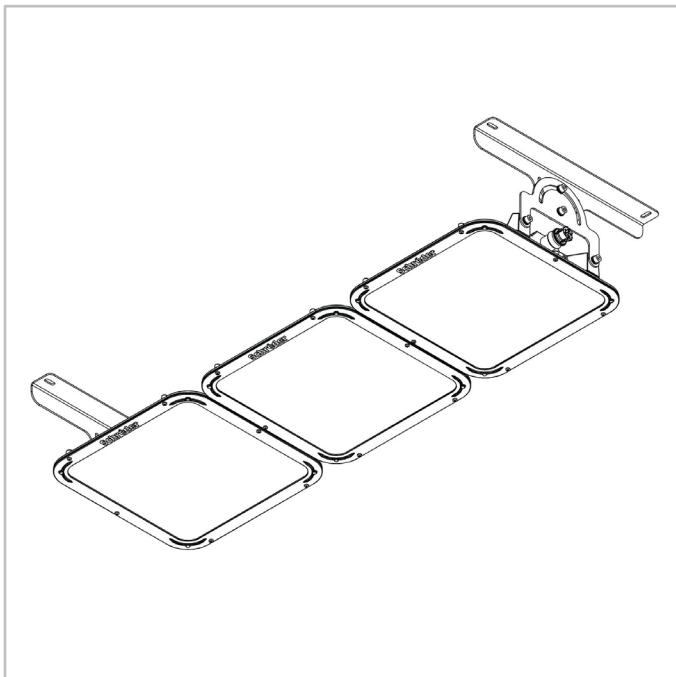

TFLEX MODULE | Pull-out swivelling wall mounting - more details in the installation sheet

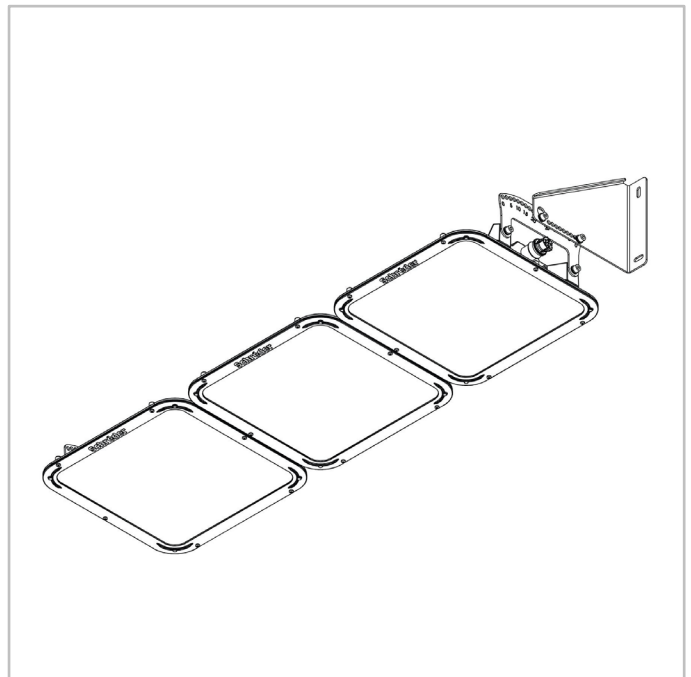

TFLEX MODULE | Adjustable swivelling wall mounting - more details in the installation sheet.

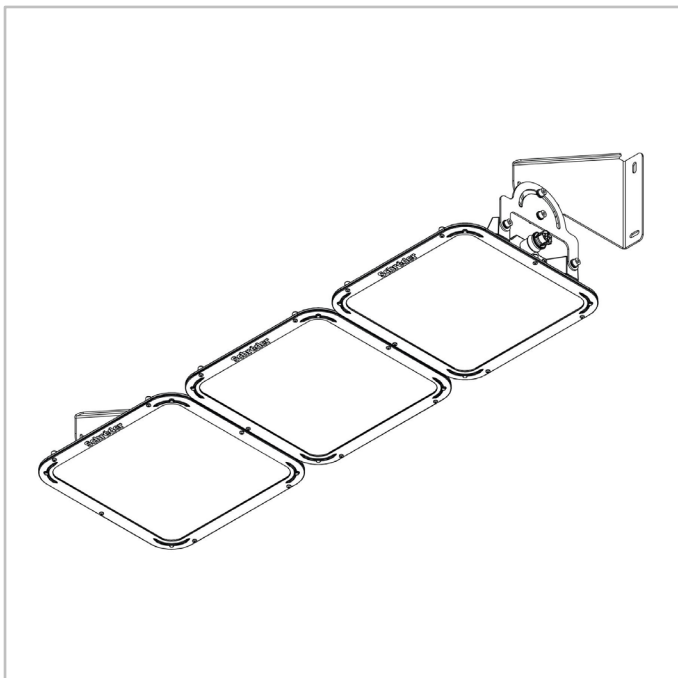

TFLEX MODULE | Hook fixation - more details in the installation sheet

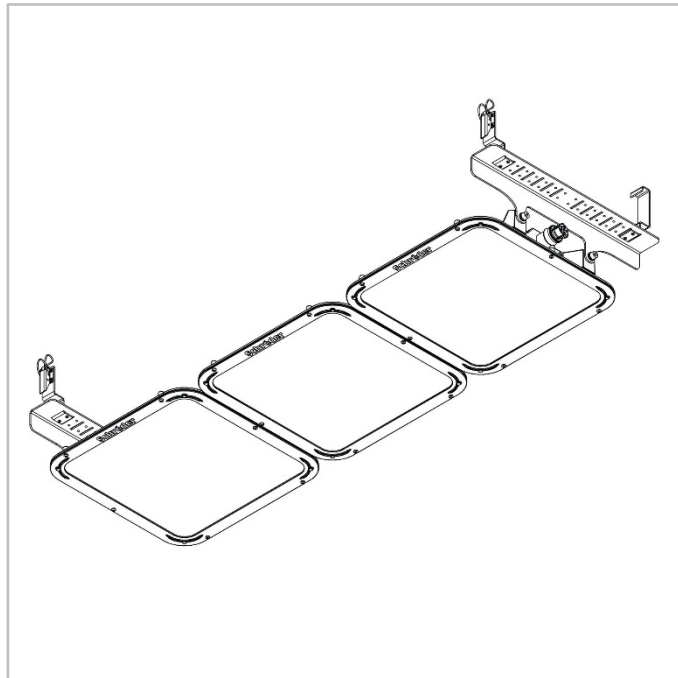



	Luminaire output flux (lm)		Power consumption (W)		Luminaire efficacy (lm/W)
	Neutral White NW 740		Min	Max	
Number of LEDs	Min	Max	Min	Max	Up to
80	12900	32700	83	264	177

Tolerance on LED flux is $\pm 7\%$ and on total luminaire power $\pm 5\%$



	Luminaire output flux (lm)		Power consumption (W)		Luminaire efficacy (lm/W)
	Neutral White NW 740		Min	Max	
Number of LEDs	Min	Max	Min	Max	Up to
120	19400	47800	128	389	172
160	25900	63800	166	508	177

Tolerance on LED flux is $\pm 7\%$ and on total luminaire power $\pm 5\%$

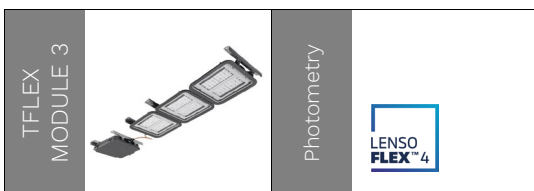

	Luminaire output flux (lm)		Power consumption (W)		Luminaire efficacy (lm/W)
	Neutral White NW 740		Min	Max	
Number of LEDs	Min	Max	Min	Max	Up to
240	69000	90100	520	640	151

Tolerance on LED flux is $\pm 7\%$ and on total luminaire power $\pm 5\%$