

# Schröder

## TFLEX DRIVE

|     |                           |     |                              |     |                          |     |                           |     |                      |
|-----|---------------------------|-----|------------------------------|-----|--------------------------|-----|---------------------------|-----|----------------------|
| ENG | INSTALLATION INSTRUCTIONS | ITA | ISTRUZIONI DI INSTALLAZIONE  | NLD | INSTALLATIE INSTRUCTIES  | DAN | INSTALLATIONSVEJLEDNING   | HUN | TELEPÍTÉSI ÚTMUTATÓ  |
| DEU | INSTALLATIONSANLEITUNG    | POL | INSTRUKCJE MONTAŻU           | RUS | Инструкции по установке  | RON | INSTRUCȚIUNI DE INSTALARE | CHI | 安装说明                 |
| FRA | INSTRUCTIONS DE MONTAGE   | SPA | INSTRUCCIONES DE INSTALACIÓN | POR | INSTRUÇÕES DE INSTALAÇÃO | SWE | INSTALLATIONSANVISNING    | UKR | Інструкції з монтажу |
| SRP | UPUTSTVA ZA INSTALACIJU   | AR  | تعليمات التركيب              |     |                          |     |                           |     |                      |

**A**

|       |                    |
|-------|--------------------|
| A     | 410 mm<br>16.14 in |
| B     | 418 mm<br>16.45 in |
| C     | 74 mm<br>2.91 in   |
| kg/lb | 12 kg<br>26.4 lb   |

**B** **FIXED BRACKETS** Ansi3G

440  
 402.5  
 22.5  
 R10  
 18.75  
 24  
 R4.5  
 22.5  
 117  
 440  
 392  
 M8  
 20 Nm  
 +1.0Nm  
 -0.0Nm

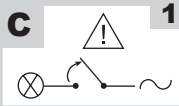

# QPD CONNECTORS

## 1 Mains and Controls separated

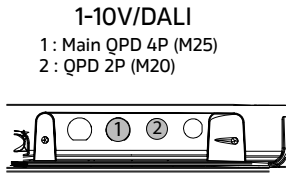

1-10V/DALI

- 1 : Main QPD 4P (M25)
- 2 : QPD 2P (M20)

- ① Mains supply
- ② Controls

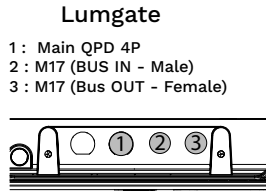
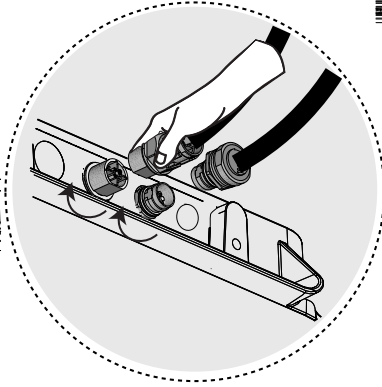

Lumgate

- 1 : Main QPD 4P
- 2 : M17 (BUS IN - Male)
- 3 : M17 (Bus OUT - Female)

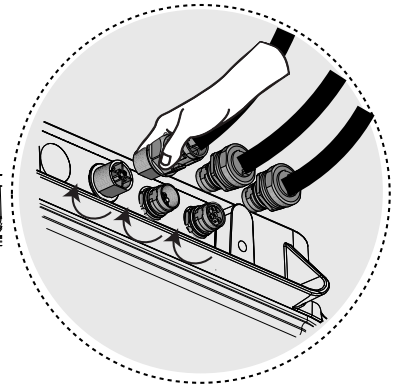

## LUMGATE

Male connector  
M17  
(IN- Pin)

Female connector  
M17  
(OUT - Bus)

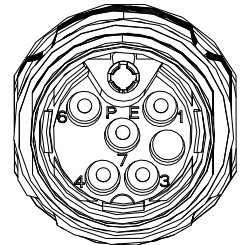
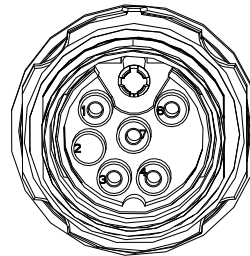

## 1a Mains and Controls combined

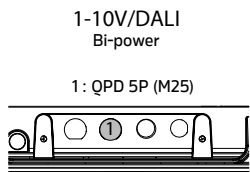

1-10V/DALI  
Bi-power

- 1 : QPD 5P (M25)

No Dim  
1 : QPD 4P (M25)

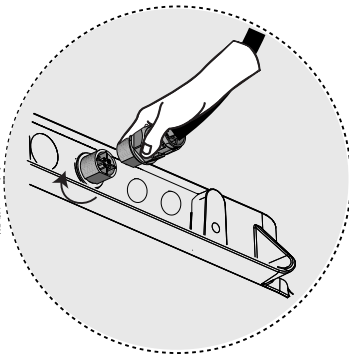

1-10V / DALI

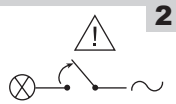
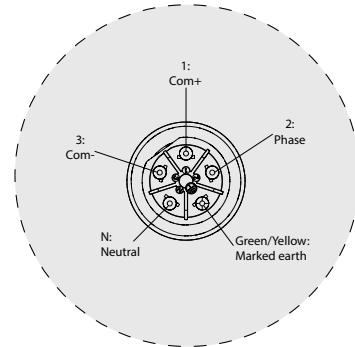

# CABLE GLANDS

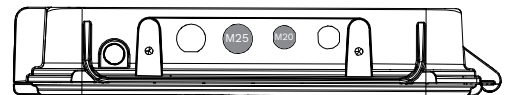

## 2a

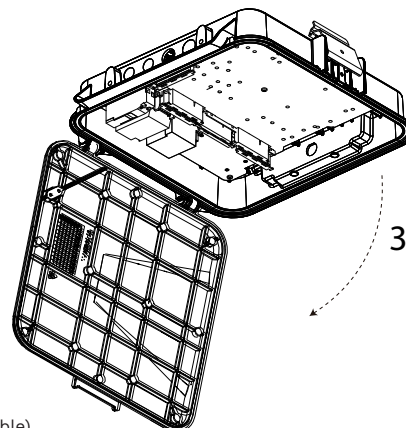
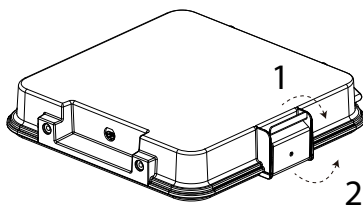

TFLEX can be equipped with QPD connectors or cable glands (delivered with or without cable).

## 2b Mains and Controls separated

**Lumgate**  
 1 : M25 cable gland  
 2 : M17 (BUS IN - Male)  
 3 : M17 (Bus OUT - Female)

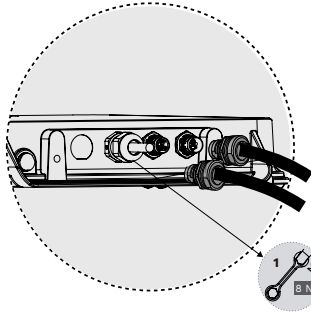

1-10V/DALI

1 : M25 cable gland  
 2 : M20 cable gland

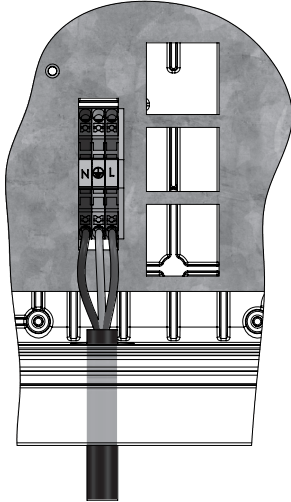
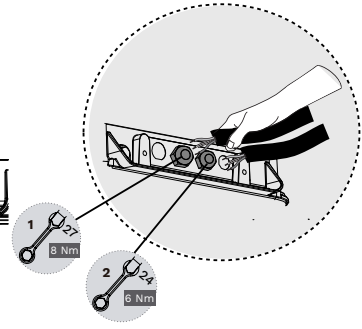

| Lumgate  |  |
|--|--|
| 1-10V / DALI   |  |
| <p><b>M25</b><br/>                     Ø6-12mm<br/>                     3x2.5mm<sup>2</sup><br/>                     3x1.5mm<sup>2</sup></p> | <p><b>M20</b><br/>                     Ø5-12mm<br/>                     2x1.5mm<sup>2</sup><br/>                     2x2.5mm<sup>2</sup></p> |

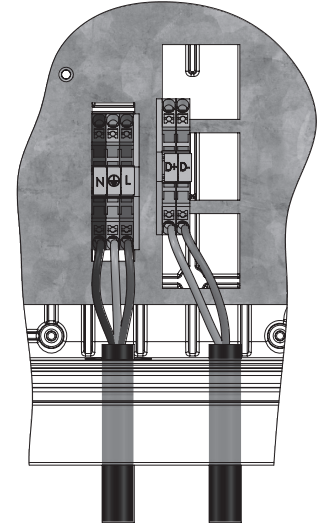

## 2c Mains and Controls combined

1-10V/DALI  
 Bi-power  
 No Dim

1 : M25 cable gland

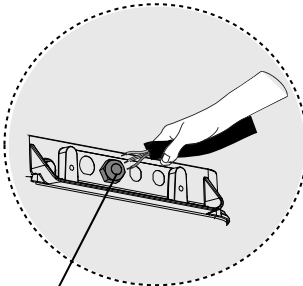
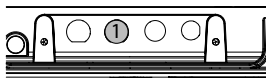

| 1-10V / DALI  | No Dim  | Bi-power  |
|---|---|---|
| <p>5x2.5mm<sup>2</sup><br/>                     5x1.5mm<sup>2</sup></p> | <p>3x2.5mm<sup>2</sup><br/>                     3x1.5mm<sup>2</sup></p> | <p>4x2.5mm<sup>2</sup><br/>                     4x1.5mm<sup>2</sup></p> |
| <b>M25</b>  | <b>M25</b>  | <b>M25</b>  |
| Ø9-14mm   | Ø6-12mm   | Ø9-14mm   |

\*(possible with (X) x 4mm<sup>2</sup> as terminals are 4mm<sup>2</sup>).

1-10V / DALI

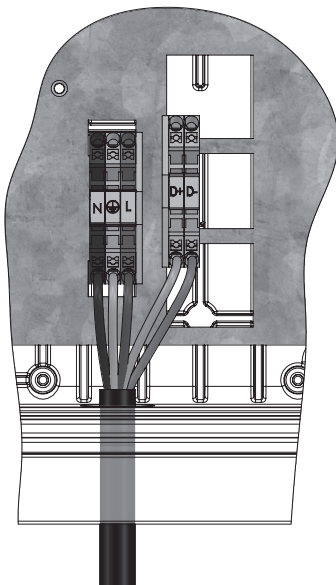

No Dim

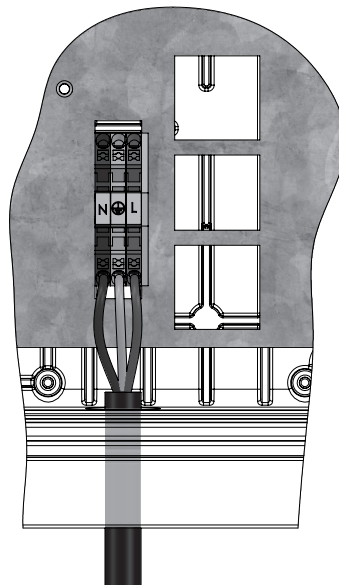

Bi-power

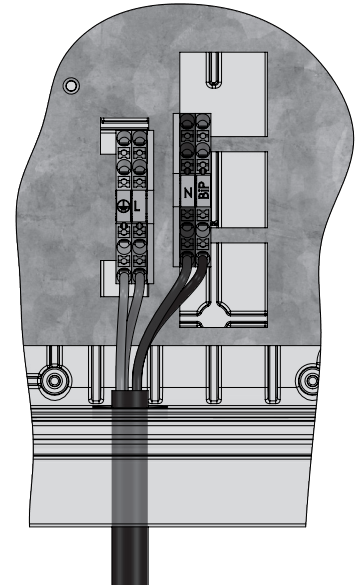

## 2d Mains and Controls separated

**Lumgate**

1: M25 cable gland  
2: M17 (BUS IN - Male)  
3: M17 (Bus OUT - Female)

1-10V/DALI

1: M25 cable gland  
2: M20 cable gland

| Lumgate   |   |
|---|---|
| 1-10V / DALI  |   |
| <br><b>M25</b><br>Ø6-12mm<br>2x2.5mm <sup>2</sup><br>2x1.5mm <sup>2</sup> | <br><b>M20</b><br>Ø5-12mm<br>2x1.5mm <sup>2</sup><br>2x2.5mm <sup>2</sup> |

## 2e Mains and Controls combined

| 1-10V /DALI   | No Dim                                       | Bi-power                                     |
|---|--|--|
|   |  |  |
| 4x2.5mm <sup>2</sup><br>4x1.5mm <sup>2</sup>                                | 2x2.5mm <sup>2</sup><br>2x1.5mm <sup>2</sup> | 3x2.5mm <sup>2</sup><br>3x1.5mm <sup>2</sup> |
| M25<br>Ø9-14mm  | M25<br>Ø6-12mm                               | M25<br>Ø9-14mm                               |
| *(possible with (X) x 4mm <sup>2</sup> as terminals are 4mm <sup>2</sup> ). |  |  |

1-10V/DALI  
Bi-power  
No Dim

1: M25 cable gland

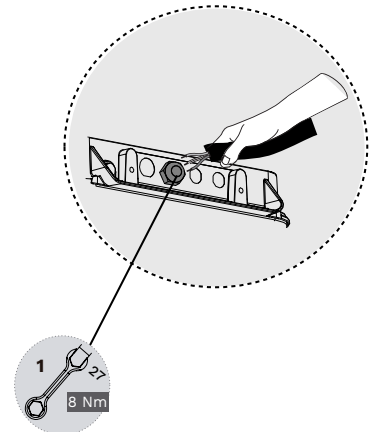

1-10V /DALI

No Dim

Bi-power

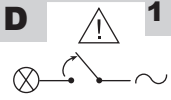

# Entry Connectors Extension

Marechal 3pin straight handle



NO DIM

Marechal 3pin angled 45 handle

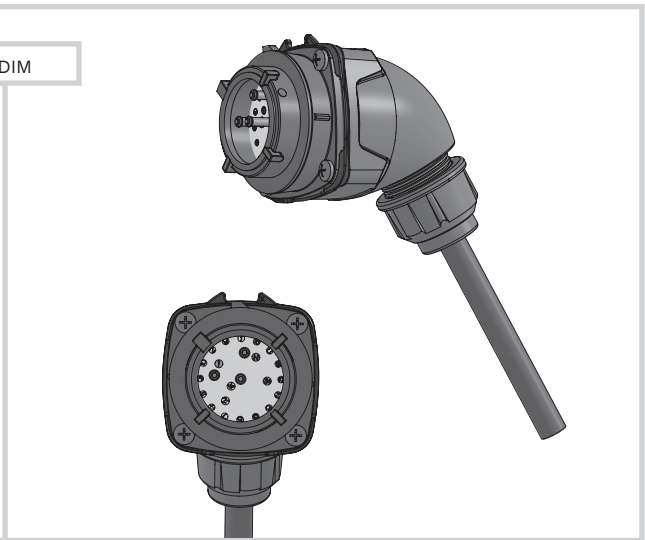

Marechal 5pin straight handle

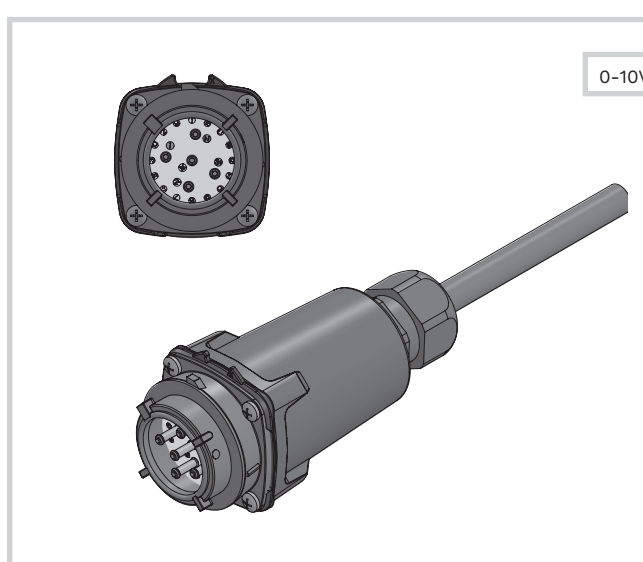

0-10V / DALI

Marechal 5pin angled 45 handle

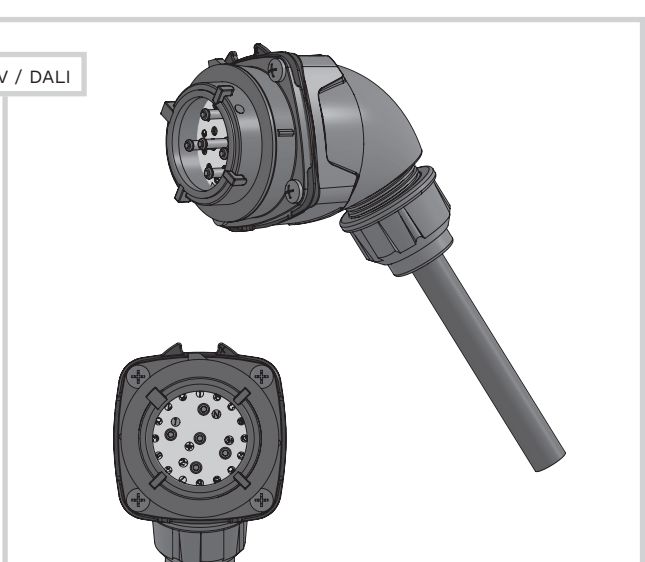

Proconect 3pin straight handle

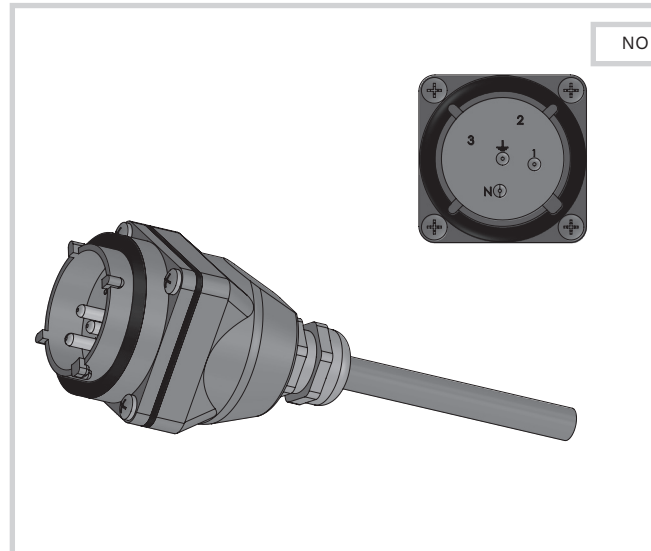

NO DIM

Proconect 3pin angled 45 handle



\* The inlets are active only for CLI EU - 230V

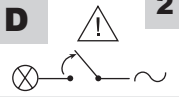

2

Dimensions of the cable depends on the inlet cable length (calculated to maintain  $L = 2, 3, 4, 5$  m)

### Proconnect 5pin straight handle

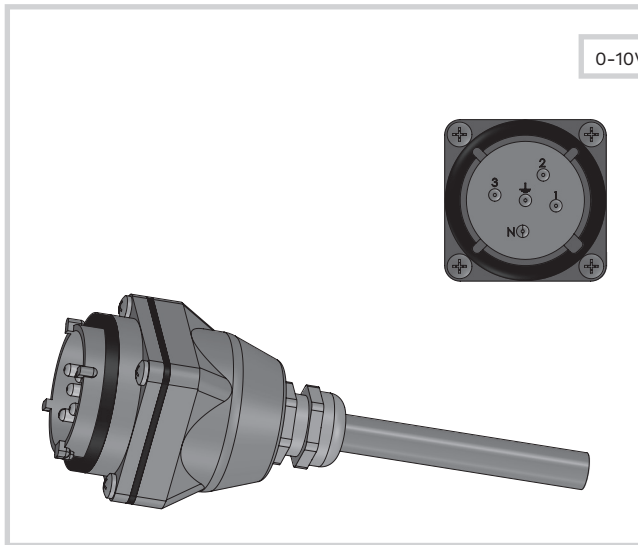

### Proconnect 5pin angled 45 handle



### 3pin straight handle IEC60309 standart

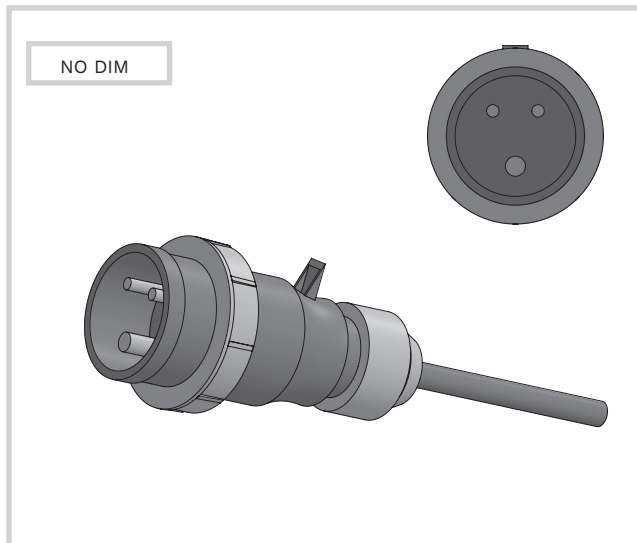

### 5pin straight handle IEC60309 standart

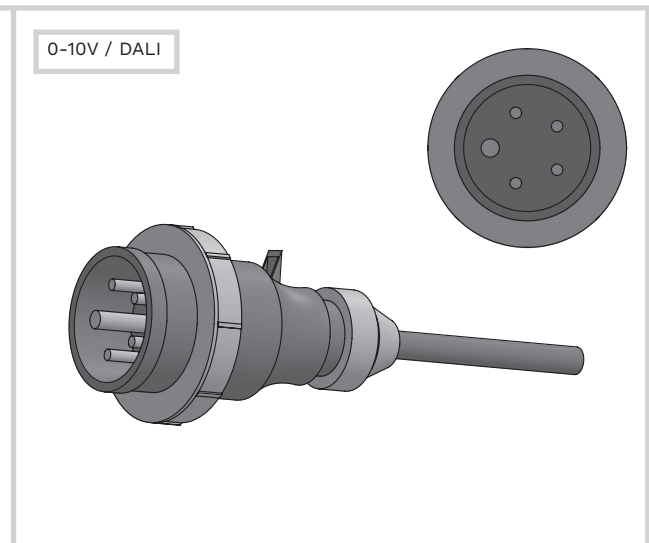

### Marechal 5pin PNC straight handle

